

# Small Diameter Automatic Round Product Labeling

## R315

### Features:

- Complete tabletop system
- Variable speed components.
- State-of-the-art control package
- Quick change product carrier
- Choose your Universal applicator
- Overhead label wrapping station.

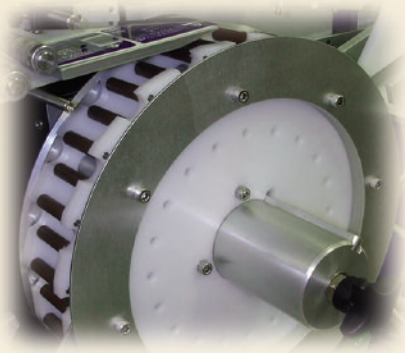

Made-to-order product carriers, accommodating virtually any small diameter product.

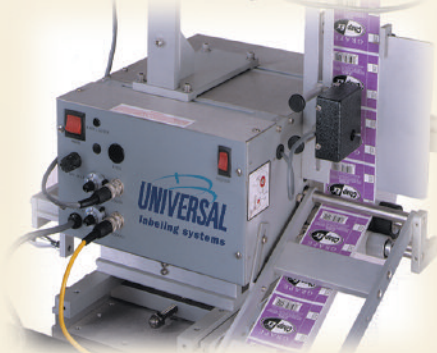

Choose your Universal applicator, including Print & Apply.

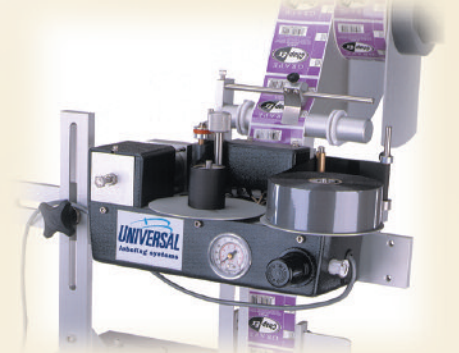

Optional hot stamp imprinter for variable information like expiration dates and lot codes.

**UNIVERSAL**  
labeling systems

Engineering  
labeling solutions.

# SPECIFICATIONS

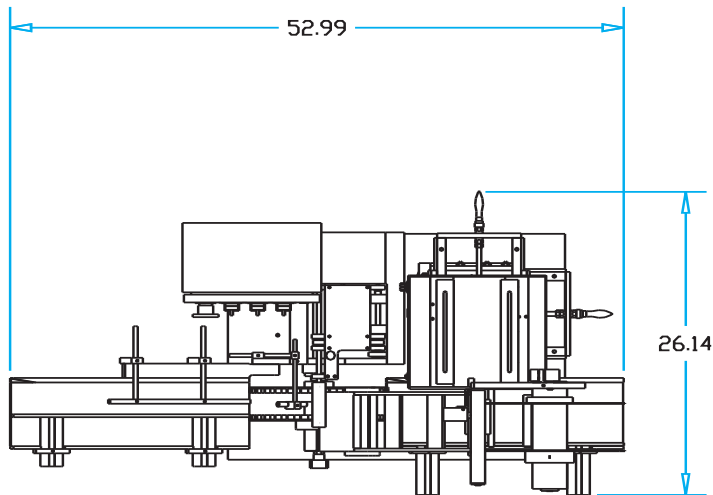

## R315

- 26" w x 53" L x 41" H
- Speed: up to 1200 inches per minute.
- 6.5" wide web capacity.
- 12" label roll capacity 3" core.
- Electric: 120 VAC+/-10%
- Unit weight: approximately 165 lbs. (Shipping weight approximately 500 lbs.)

## Options

- Additional product carriers
- Framework base with casters and leveling pads
- SL1500 label applicator or UPA II Printer Applicator
- Automatic speed following
- Vibrating in-feed chute assembly with motor
- Hot stamp imprinter

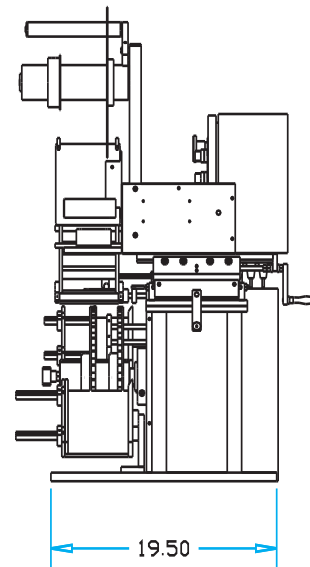
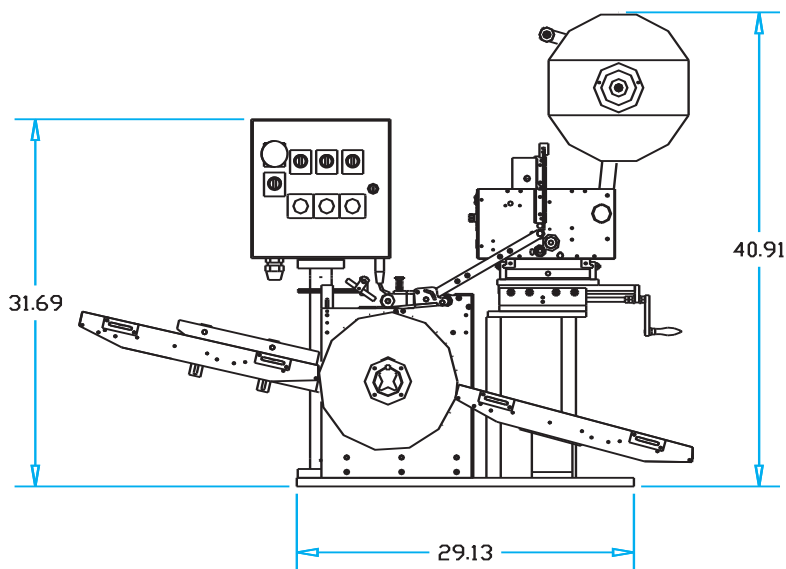

### Universal Labeling Systems, Inc.

3501 8th Avenue South • St. Petersburg, FL 33711

1-877-236-0266 • sales@universal1.com

www.universal1.com